



## Application

The W370 is a modern ultrasonic cold or hot water meter with a lead-free measuring tube, designed as a basis for a modern, digitalized water supply network.

## Key Facts

- Ultrasonic measurement - precise, durable
- Optional upstream leak detection
- Large, easy readable display
- Data logger and Logbook
- NFC interface
- wM-Bus, LoRaWAN® or NB-IoT interface
- Lead free brass tube
- 15 years of battery lifetime with Intelligent battery management

## Technical Data

Metrology	
Measuring accuracy	Class 2 (OIML R49)
Dynamic range	R250, R160 (Max. R400)
Temperature class	T50 (cold water) T70 (warm water)
Measuring interval	1 Hz
Approvals	
Metrological	MID, NMI
Hygienic	UBA, WRAS, ACS, ICIM Australian WaterMark, RCM
Others	Complies with the Lead Free requirements of the National Construction Code Vol.3
Data storage	
Logbook	Yes: Tracking of 41 events (type, timestamp)
Datalogger	Yes
Datalogger data	Set of up to 9 values
Datalogger depth	15 years/72 months/400 days/744 hours
Installation	
Nominal size	DN15, DN20
Nominal flow	2.5 m <sup>3</sup> /h, 4 m <sup>3</sup> /h
Pressure class	MAP 16 (16 bar)
Orientation	V/H (any orientation)
Strainer	Yes
Non return valve	Yes (optional): single/double

Wetted surfaces	Lead free brass CW724R PA GF40 Stainless steel
Pressure loss	ΔP40, ΔP63
Environmental conditions	
Environment class	O (OIML R49) for outdoor installation
Mechanical class	M1 (MID)
Electromagnetical class	E2 (MID)
Ingress Protection	IP68
Max. height	2000 m above sea level
Operating temperature	-10 ... 65°C (inside housing)
Storage temperature	-20 ... 70 °C (inside housing)
UV protection	stabilized
Power supply	
Power supply	1x D cell lithium battery (5g lithium)
Battery lifetime	15 years + 2 year in storage mode
Display	
Resolution	Volume: 0.001 m <sup>3</sup>
Digits	Volume: 9 (6.3) Flow: 5
Information	Volume, flow, alarms, flow direction, battery status, communication status, signal strength
Other	
App support	Yes (service app, consumer app)
Data security	X.509 certificate based access protection



### Technical Data

Nominal flow Q3	2.5	2.5	2.5	2.5	4	4	4	4	[m³/h]
Overall length	110	165	134	190	105	130	154	190	[mm]
Connection	G ¾	G ¾	G 1	G 1	G 1	G 1	G 1	G 1	
Nominal size	DN15	DN15	DN20	DN20	DN20	DN20	DN20	DN20	
Maximum flowrate Q4	3.125	3.125	3.125	3.125	5	5	5	5	[m³/h]
Minimum flowrate Q1 @ R250	10	10	10	10	16	16	16	16	[l/h]
Response threshold (variable)	2	2	2	2	3	3	3	3	[l/h]
Overflow	5	5	5	5	8	8	8	8	[m³/h]
Q3/Q1max	R250	R400, R250*	R400, R250*	R400	R400	R400	R250	R400	
Pressure loss class	400	400	400	400	630	630	630	630	[mbar]
Pressure loss	283	340	425	357	441	421	408	432	[mbar]
Vibration sensor (Leak detection)	-	-	-	available	-	-	available	available	
Weight	440	500	540	630	510	540	560	630	[g]

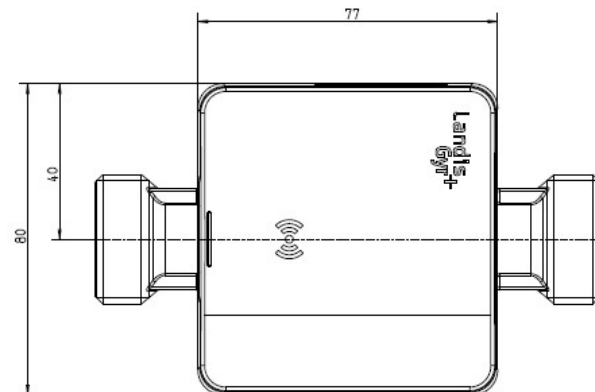
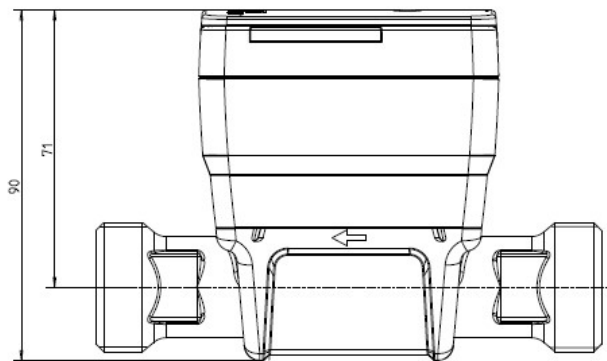

\* T70



**Communication (LoRa or wM-Bus or NB-IoT)**

RF interface (LoRa® and wM-Bus Switchable)	
<b>LoRa®</b>	
Version	1.0.3
Frequency band	868 MHz
Class	A (bidirectional)
Activation	OTA or ABP
Payload format	M-Bus
Transmission interval	1h, 8h, 12h, 24h
Automatic commissioning	Yes
Downlink parameterisation	Yes
<b>wM-Bus</b>	
Standard	Open Metering System Specification OMS (Version 4) EN 13757-4; Mode T1, C1
Frequency band	868 MHz
Transmission power	10 dBm
Range	
- Free field	Up to 400 m
Battery lifetime	Up to 15 a
Sending interval	
- Mobile data reading	30 Seconds
- Stationary data reading	15 Minutes
- User defined data reading	Acc. to telegram length 12 - 900 Seconds
Data telegram	8 predefined data telegrams User defined data telegram with Service Software

NB-IoT	
Standard	NB1 & NB2
Carriers	L+G (Vodafone), others on request
Protocol	OMA LwM2M
Battery lifetime	15 a (@daily transmissions)
Over the air updates	Yes (whole meter firmware)
3GPP	Version 13, 14
Transmission intervals	8h, 12h, 24h
Automatic commissioning	Yes
Downlink parameterisation	Yes
Special functions	Instantaneous alarm transmission Queuing (resume failed transmissions) Downlink parameterisation Dynamic data logger transmissions
Frequency bands	3 (1805-1880 MHz), 5 (869-894 MHz), 8 (925-960 MHz), 20 (791-821 MHz), on request: 28 (758-803MHz)